

# XL COMPACT PISTON MULTI-CAM MOTORS

## OUTPUT CONFIGURATIONS

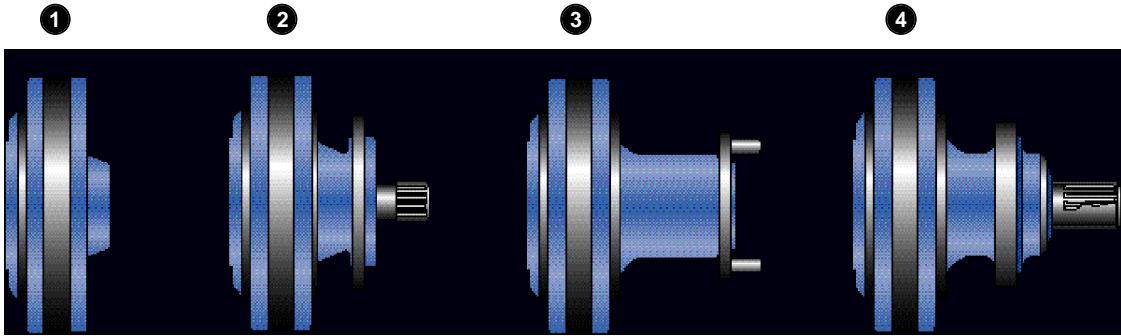

XL motors may be supplied in the four configurations shown above. It is possible to supply a shaft motor with wheel housing if required.

Which configuration to use :-

1.	Torque Unit	No axial / radial loading. Integration into machine / gearbox drives - mobile / industrial.
2.	Compact Motor	Light or no axial / radial loading and gearbox drives - mobile / industrial.
3.	Wheel Motor	High radial / axial loading and long life - mobile / industrial.
4.	Shaft Motor	High radial / axial loading and long life - mobile / industrial.

## XL MOTOR OPERATION

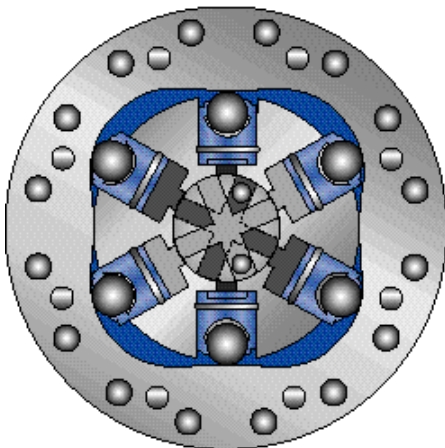

Oil is fed under pressure through the valve and into the cylinders. The pistons attempt to move outwards. The rollers react on the incline of the cam profile and this action produces rotation of the cylinder block.

Each piston completes four strokes per revolution of the motor. The symmetrical arrangement balances hydraulic forces, eliminating the need for bearings.

## XL MOTOR TECHNICAL DATA

		XL150	XL200	XL280	XL390	XL490	XL560	XL780	XL880	XL980	XL1050	XL1120
<b>Geometric Displacement</b> (CM3)		150	200	280	390	490	560	780	880	980	1050	1120
<b>Max Speed Rev/Min</b>	<i>Cont.</i>	550	500	390	440	350	320	230	200	180	170	160
	<i>Int*</i>	600	600	550	500	500	450	320	285	255	240	225
	<i>Freewheel</i>	1000	1000	1000	850	850	850	850	850	850	850	850
<b>Max Torque (Nm)</b>	<i>Cont</i>	480	640	890	1250	1570	1790	2500	2820	3140	3355	3680
	<i>Int*</i>	790	1050	1480	2060	2590	2590	4120	4650	5180	5530	5900
	<i>Peak**</i>	930	1240	1740	2420	3040	3460	4840	5460	6080	6480	6920
<b>Max Output kW</b>	<i>Cont</i>	18	18	18	30	30	30	60	60	60	60	60
	<i>Int*</i>	30	30	30	50	50	50	100	100	100	100	100
<b>Max Pressure (Bar)</b>	<i>Cont</i>	210	210	210	210	210	210	210	210	210	210	210
	<i>Int*</i>	350	350	350	350	350	350	350	350	350	350	350
	<i>Peak**</i>	420	420	420	420	420	420	420	420	420	420	420
<b>Max Oil Flow (L/Min)</b>	<i>Cont</i>	87	105	109	178	178	178	178	178	178	178	178
	<i>Int*</i>	95	128	154	205	251	251	251	251	251	251	251
<b>Outlet Pressure (Bar)***</b>	<i>Min</i>	2	2	2	2	2	2	2	2	2	2	2
	<i>Max</i>	20	20	20	20	20	20	20	20	20	20	20
<b>Case Pressure (Bar)</b>	<i>Max</i>	7	7	7	7	7	7	7	7	7	7	7
<b>Fluid Type</b>		HL; HLPto DIN 51524 (for alternative fluid types contact Rotary Power)										
<b>Fluid Min/Max Viscosity</b>		15 to 2000 cSt										
<b>Optimum Viscosity</b>		35 to 200 cSt										
<b>Operating Temp (°C) Min/Max</b>		-30°C to +80°C										
<b>Optimum</b>		+40°C to +70°C										
<b>Fluid Cleanliness</b>		NAS 1638 Class 9/ISO Code 18/15										
<b>FILTRATION</b>		<b>TO 10 RATIO 75 OR BETTER</b>										
<b>Min Starting Torque (Nm)</b>	At 210 Bar Press. Cont.	420	560	790	1100	1390	1580	2210	2500	2780	2980	3180
	At 350 Bar Press. Cont.	710	940	1320	1840	2320	2640	3670	4140	4610	4940	5270

\* Permissible intermittent values may occur for up to 10% of every minute as part of a known duty cycle (Typical maximum pressure for mobile applications).

\*\* Peak loads may occur for up to 1% of every minute.

\*\*\* Outlet Pressure required above case pressure.

## CASE DRAIN FLOW

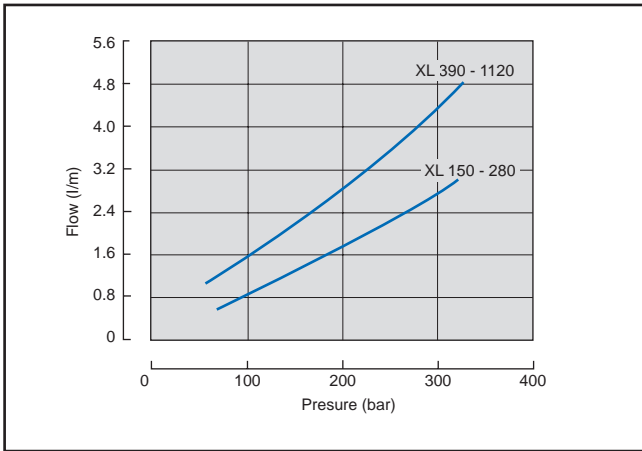

Case drain figures should be added to other circuit losses in closed loop systems to arrive at loop make-up requirements. Installation should be designed to prevent siphoning of oil from the motor case.

Where continuous operation is above 300 min<sup>-1</sup> it may be necessary to provide a cooling flow through the case, typically 1-2 litres/min. The need for cooling flow depends upon duty, fluid environment etc.

Case drain is located on the pintle and should be positioned uppermost.

## NO LOAD PRESSURE DROP

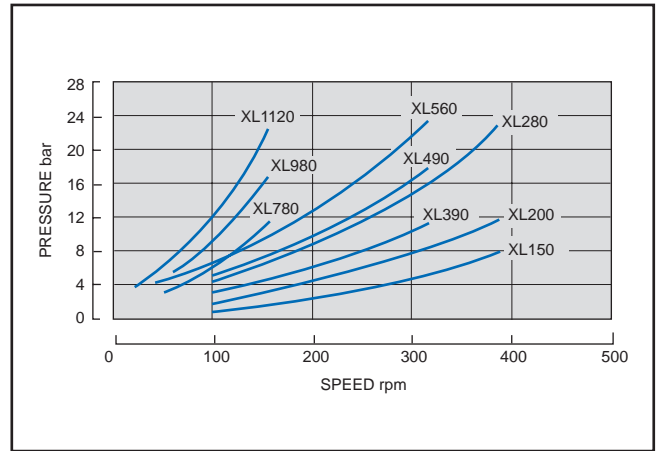

The differential pressure across the supply ports required to drive the motor over its speed range with the output shaft disconnected.

## BOOST PRESSURE

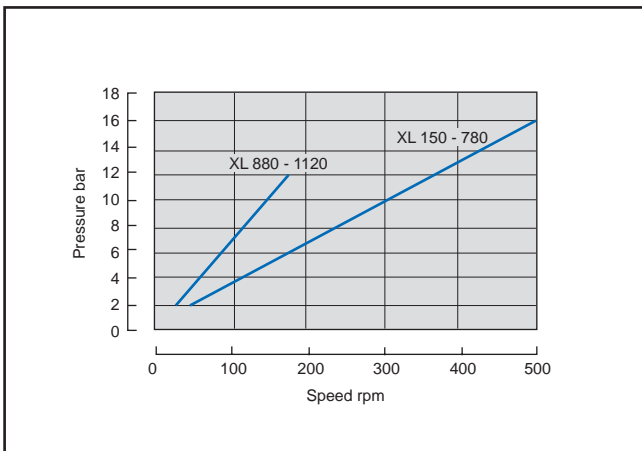

Where the load can overrun the motor (i.e. motor operating as a pump) it is important to ensure sufficient supply boost pressure to avoid incomplete filling of the cylinders and cavitation. The minimum boost pressure required at the motor inlet port is equal to the sum of the boost pressure from the graph and the actual case pressure.

## FREE WHEELING

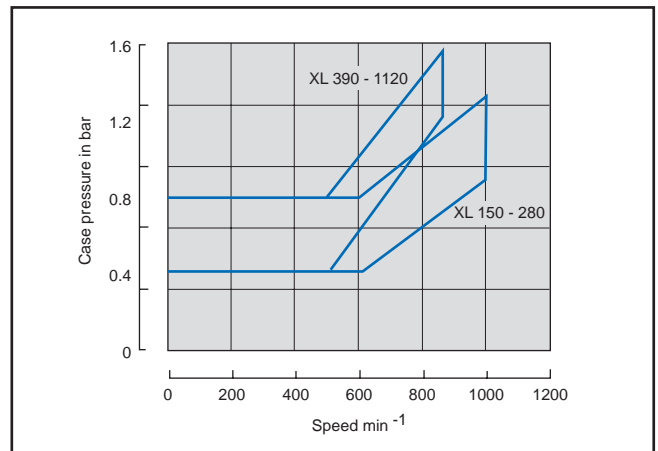

Case pressure (differential over port pressure) required to retract the pistons for freewheeling operation is shown in the graph above. The transition into and out of the freewheeling mode is normally accomplished with the motor stationary.

## WHEEL AND SHAFT MOTORS

### Type XLA XLB XLE

Output shafts run in taper bearings that permit high axial and radial forces. Due to the unique design of the XL, the shaft bearings are not affected by system pressure.

### Compact Motor

Even though this is a type XLC lightweight output housing moderate radial and axial loading is permissible. The curves apply to a B10 bearing life of 3000 hours at 110 rev/min when mineral-based hydraulic oil with anti-wear additions and to specification DIN 51424 is used. The graphs are drawn for a 40cSt oil.

### Effect of shaft speed on life

Because L10 life and speed are inversely proportional to each other, bearing life for speeds other than 110 rpm can easily be calculated, i.e. half speed gives twice life. To calculate the bearing life for a different speed :

$$L_{10 \text{ new}} = 3000 \times \frac{110 \text{ rev/min}}{\text{new rev/min}}$$

### Effect of shaft load on life

If the radial load is less than that shown by the curve, bearing life will be longer than 3000 hours. Assuming the speed is set at 110 rev/min (if not, adjust as shown above) bearing life may be calculated using :

$$L_{10 \text{ new}} = 3000 \times \left[ \frac{\text{curve load}}{\text{new load}} \right]^{3.33^\circ}$$

### Effect of shaft speed on permissible shaft load

Applications such as vehicle propulsion using wheel motors can produce conditions of high load and relatively low speed. In such conditions permissible shaft load must always remain within the mechanical strength limitations.

To calculate permissible shaft load :

$$\text{New load} = \text{Load from curve} \times 3.33 \sqrt{\frac{110}{\text{new speed}}}$$

If you are in any doubt contact Rotary Power Applications Department.

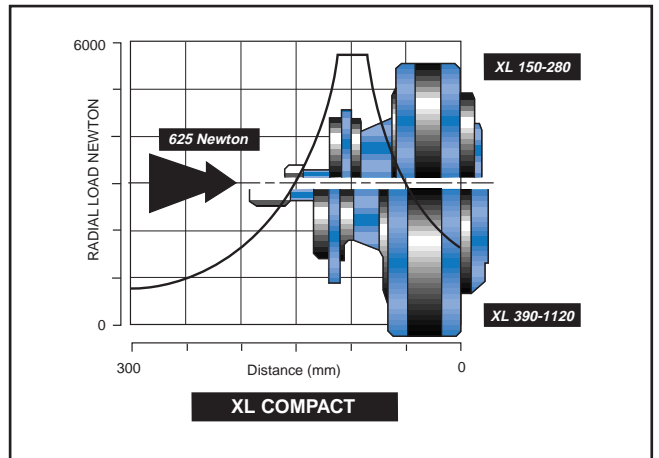
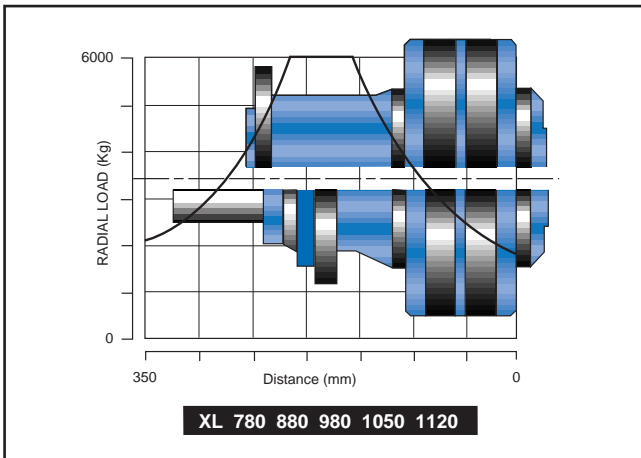
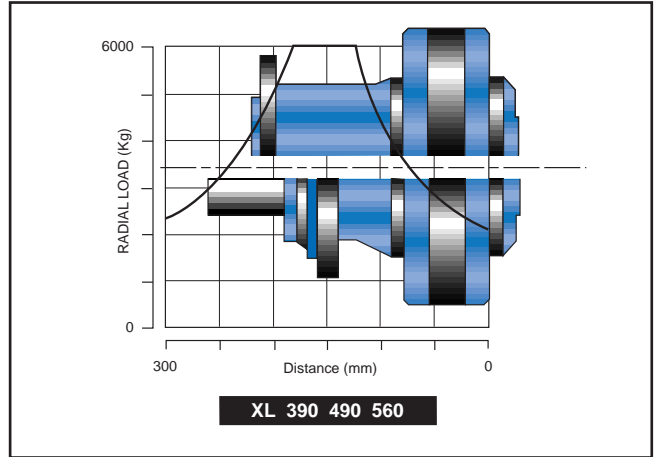
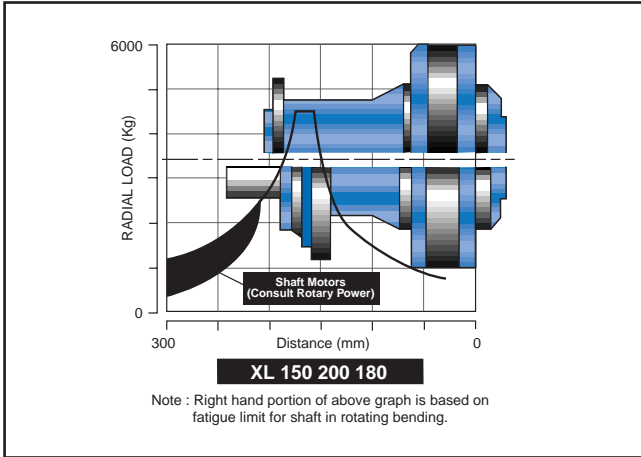

# XLA XLB SHAFT MOTORS

Before finalising your installation please ask for a copy of the latest issue drawing.

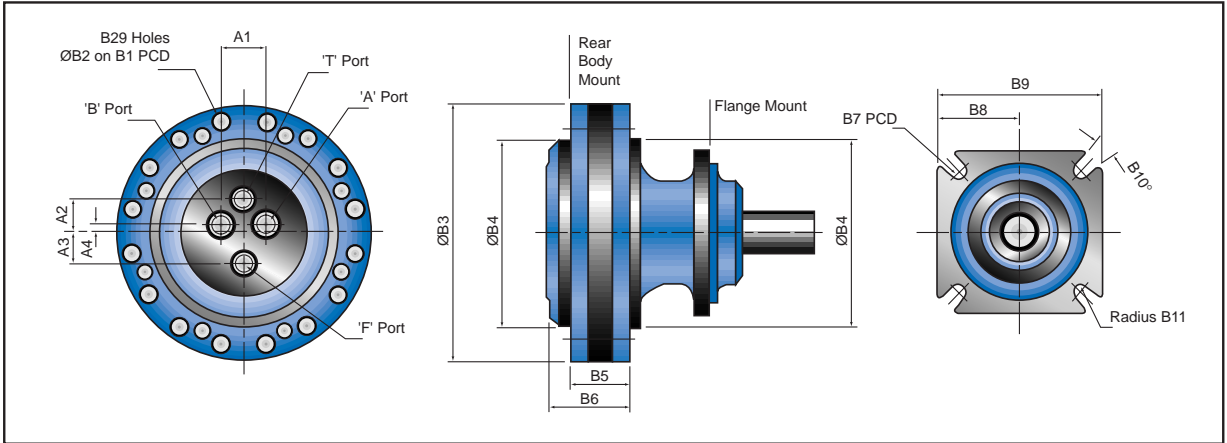

## XLA \_\_ A \_\_ 000 \_\_

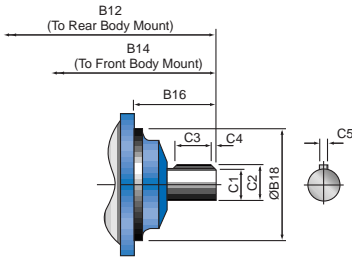

## XLB \_\_ B \_\_ 000 \_\_

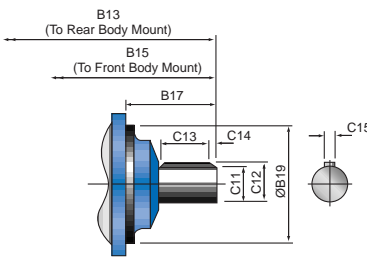

## XLB \_\_ F \_\_ 000 \_\_

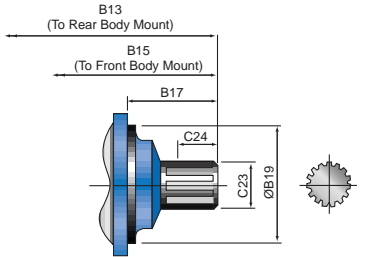

## XLA \_\_ D \_\_ 000 \_\_

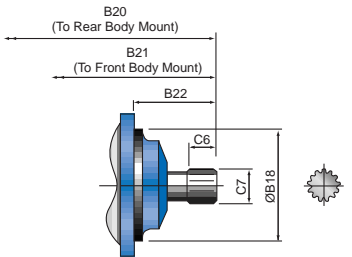

## XLB \_\_ C \_\_ 000 \_\_

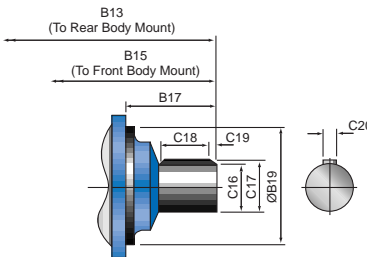

## XLA \_\_ H \_\_ 00 \_\_

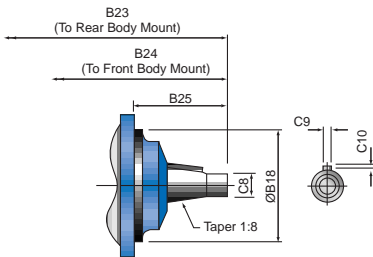

## XLB \_\_ E \_\_ 000 \_\_

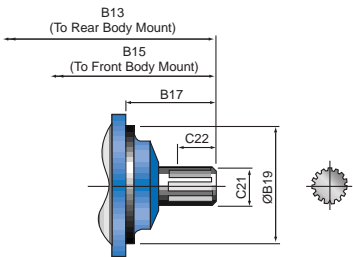

## DIMENSIONS XLA XLB SHAFT MOTORS

HYDRAULIC CONNECTIONS			
	<i>XL150</i> <i>XL200</i> <i>XL280</i>	<i>XL390</i> <i>XL490</i> <i>XL560</i>	<i>XL780</i> <i>XL980</i> <i>XL1120</i>
* 'A' Port	5/8 SAE	5/8 SAE	5/8 SAE
* 'B' Port	5/8 SAE	5/8 SAE	5/8 SAE
* 'T' Port	3/8 SAE	1/2 SAE	1/2 SAE
* 'F' Port	3/8 SAE	1/2 SAE	1/2 SAE
A1	45	52	52
A2	33	38	38
A3	28	36	36
A4	5.5	9	9

MOUNTING INFORMATION			
	<i>XL150</i> <i>XL200</i> <i>XL280</i>	<i>XL390</i> <i>XL490</i> <i>XL560</i>	<i>XL780</i> <i>XL980</i> <i>XL1120</i>
B1	210	265	265
B2	14.25/13.90	17.75/17.40	17.75/17.40
B3	237	298	298
B4	180.0/179.95	216.0/215.82	216.0/215.82
B5	62	70	105
B6	84	95	130
B7	160	200	200
B8	74	95	95
B9	148	190	190
B10	17°	11°	11°
B11	7	9	9
B12	270.0	270.2	N/A
B13	270.0	285.5	320.5
B14	208.0	200.2	N/A
B15	208.0	215.5	250.5
B16	118.6	110.2	N/A
B17	114.0	122.5	122.5
B18	127.0/126.95	152.4/152.35	152.4/152.35
B19	125.0/124.94	160.0/159.94	160.0/159.94
B20	242.0	270.2	N/A
B21	180.0	200.2	N/A
B22	90.6	110.2	N/A
B23	270.0	285.5	320.5
B24	208.0	215.5	250.5
B25	118.6	125.5	125.5

OUTPUT SHAFT INFORMATION			
	<i>XL150</i> <i>XL200</i> <i>XL280</i>	<i>XL390</i> <i>XL490</i> <i>XL560</i>	<i>XL780</i> <i>XL980</i> <i>XL1120</i>
C1	38.1/38.05	44.45/44.4	N/A
C2	42.4/42.14	49.30	N/A
C3	70.0	50.0	N/A
C4	5.0	5.0	N/A
C5	9.55/9.53	11.14/11.11	N/A
C6	26.0	36.0	N/A
C7	ANSI B92.1 17T 12/24P	ANSI B92.1 13T 8/18P	N/A
C8	1 1/8-12 UNF	1 1/4-12 UNF	1 1/4-12 UNF
C9	9.55/9.53	11.14/11.11	11.14/11.11
C10	4.93/4.67	5.715/5.461	5.715/5.461
C11	40.018/40.002	50.018/50.002	N/A
C12	43.018/42.759	53.518/53.212	N/A
C13	70.0	70.0	N/A
C14	5.0	5.0	N/A
C15	12.0/11.91	14.043/14.0	N/A
C16	50.018/50.002	65.03/65.01	65.03/65.01
C17	53.40	68.90	68.90
C18	70.0	65.0	65.0
C19	5.0	10.0	10.0
C20	14.0/13.96	18.0/17.96	18.0/17.96
C21	DIN5480 W40x3x12x7H	DIN5480 W50x3x15x7H	N/A
C22	50.0	53.0	N/A
C23	BS3550 17T 8/16P	BS3550 14T 6/12P	BS3550 14T 6/12P
C24	50.0	54.0	54.0

\* Hydraulic connection sizes denote SAE 'O' ring boss size. These are not thread dimensions.

# WHEEL DRAWINGS

Before finalising your installation please ask for a copy of the latest issue drawing.

## WHEEL MOTORS 150 - 560 CC/REV

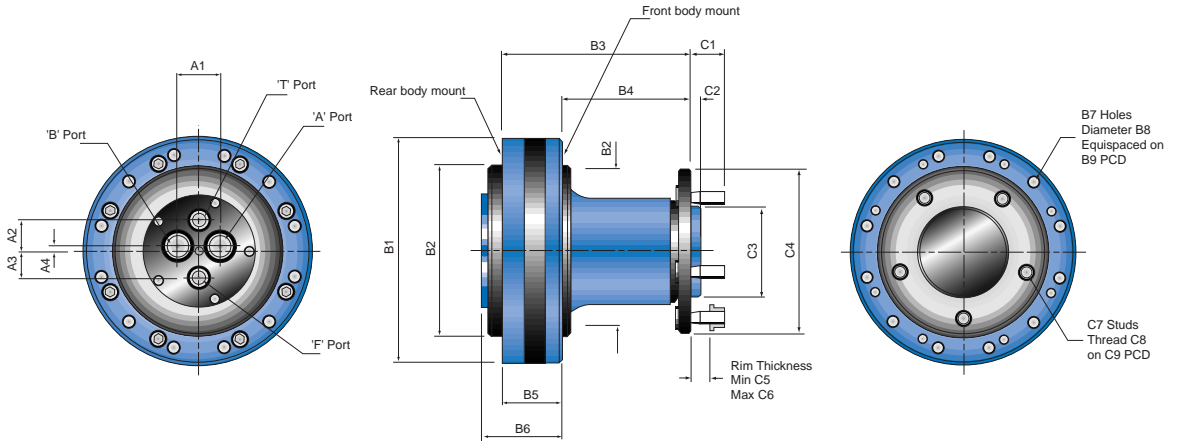

## WHEEL MOTORS 780 - 1120 CC/REV

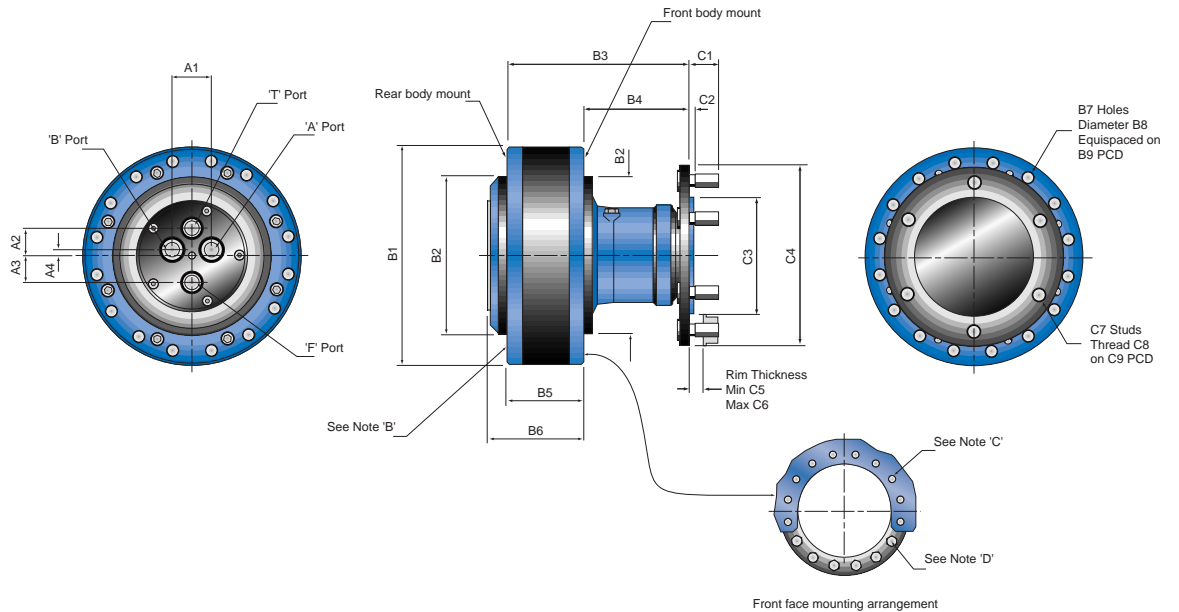

## WHEEL DIMENSIONS

HYDRAULIC CONNECTIONS			
	XL150 XL200 XL280	XL390 XL490 XL560	XL780 XL980 XL1120
* 'A' Port	5/8 SAE	5/8 SAE	5/8 SAE
* 'B' Port	5/8 SAE	5/8 SAE	5/8 SAE
* 'T' Port	3/8 SAE	1/2 SAE	1/2 SAE
* 'F' Port	3/8 SAE	1/2 SAE	1/2 SAE
A1	45	52	52
A2	33	38	38
A3	28	36	36
A4	5.5	9	9

OUTPUT SHAFT INFORMATION			
	XL150 XL200 XL280	XL390 XL490 XL560	XL780 XL980 XL1120
C1	35	35	41
C2	10	7	7
C3	95.80/95.60	95.80/95.60	160.80/160.60
C4	173	170	247.5
C5	10.0	10	10
C6	20.0	20	20
C7	5	5	6
C8	M14-1.5P	M14-1.5P	M18-1.5P
C9	140	140	205

MOUNTING INFORMATION			
	XL150 XL200 XL280	XL390 XL490 XL560	XL780 XL980 XL1120
B1	237	298	298
B2	180.00/179.95	216.00/215.82	216.00/215.82
B3	196	211.6	246.6
B4	134	142	142
B5	62	70	105
B6	84	95	130
B7	12	16	16
B8	14.25/13.90	17.75/17.40	17.75/17.40
B9	210	265	265

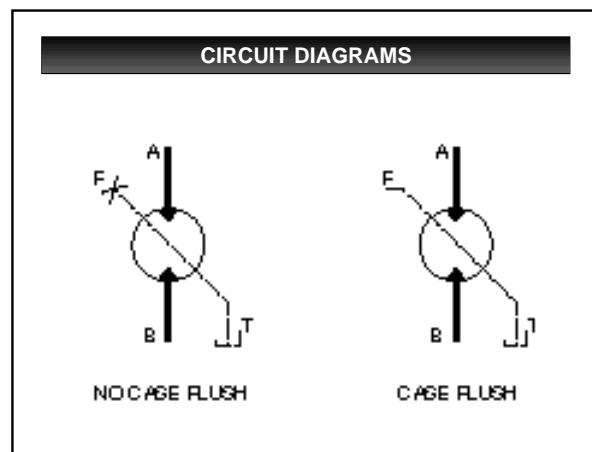

\* Hydraulic connection sizes denote SAE 'O'ring boss size. These are not thread dimensions.

### NOTES FOR MOUNTING

- For motors from 150 CC/Rev to 280 CC/Rev. All 12 mounting holes should be used for front or rear body mounting unless otherwise agreed by Rotary Power.
- For motors from 390 CC/Rev to 1120 CC/Rev. All 16 mounting holes should be used for rear body mounting.
- For motors from 390 CC/Rev to 1120 CC/Rev. Mount motor using 10 off M16 bolts (min grade 8.8) tightened to 210/220 Nm Torque.
- For motors from 780 CC/Rev to 1120 CC/Rev. Clamp 6 off remaining holes using M16 bolts (min grade 8.8) tightened to 210/220 Nm Torque.



# XLC COMPACT UNIT

Before finalising your installation please ask for a copy of the latest issue drawing.

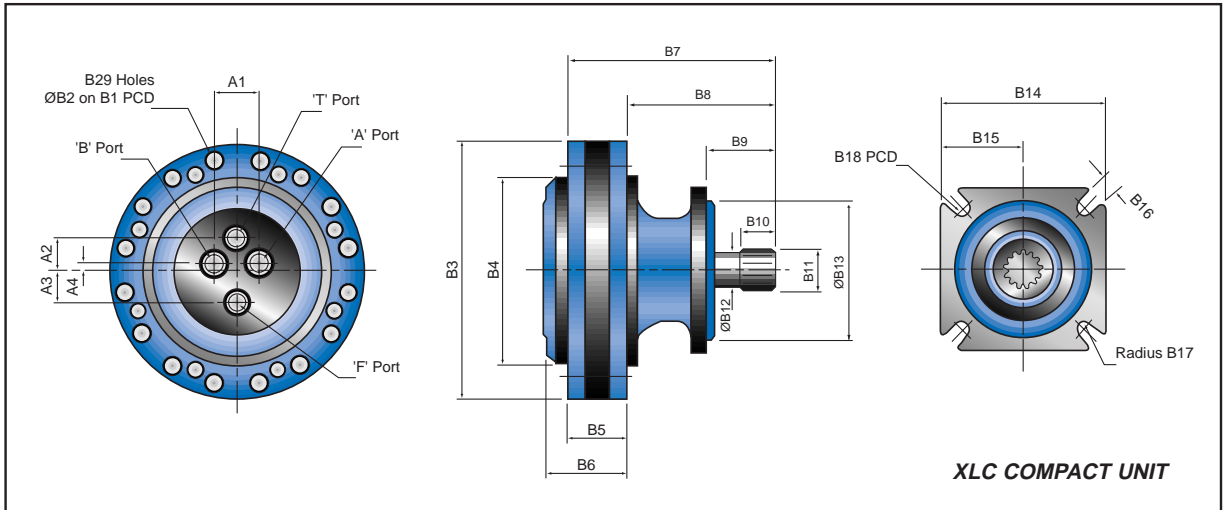

**XLC COMPACT UNIT**

## XLC & XLO DIMENSIONS

### HYDRAULIC CONNECTIONS

	<i>XL150</i> <i>XL200</i> <i>XL280</i>	<i>XL390</i> <i>XL490</i> <i>XL560</i>	<i>XL780</i> <i>XL980</i> <i>XL1120</i>
* 'A' Port	5/8 SAE	5/8 SAE	5/8 SAE
* 'B' Port	5/8 SAE	5/8 SAE	5/8 SAE
* 'T' Port	3/8 SAE	1/2 SAE	1/2 SAE
* 'F' Port	3/8 SAE	1/2 SAE	1/2 SAE
A1	45	52	52
A2	33	38	38
A3	28	36	36
A4	5.5	9	9

### MOUNTING INFORMATION

	<i>XL150</i> <i>XL200</i> <i>XL280</i>	<i>XL390</i> <i>XL490</i> <i>XL560</i>	<i>XL780</i> <i>XL980</i> <i>XL1120</i>
B1	210	265	265
B2	14.25/13.90	17.75/17.40	17.75/17.40
B3	237	298	298
B4	180.0/179.95	216.0/215.82	216.0/215.82
B5	66	69	104
B6	88	94	129
B7	170.4	206	241
B8	108.4	136	137
B9	55.4	75	75
B10	17.0	36.0	50

### MOUNTING INFORMATION (cont)

	<i>XL150</i> <i>XL200</i> <i>XL280</i>	<i>XL390</i> <i>XL490</i> <i>XL560</i>	<i>XL780</i> <i>XL980</i> <i>XL1120</i>
B11	ANSI B92.1 14T 12/24P	ANS B92.1 13T 8/16P	DIN5480 B50x2x24x7h
B12	26.7	37.0	49.5
B13	127.0/126.95	152.4/152.35	152.4/152.35
B14	148	200	200
B15	74	100	100
B16	14.0	20.6	20.6
B17	7.0	10.3	10.3
B18	160.0	228.6	228.6
B19	109	120	155
B20	77	97	97
B21	90	124	124
B22	160.04/160.00	190.04/190.00	190.04/190.00
B23	7.8	8.0	8.0
B24	BS3550 29T 16/32P (SP.)	DIN5482 A50x45	DIN5480 70x3x30x22

\* Hydraulic connection sizes denote SAE 'O' ring boss size. These are not thread dimensions.

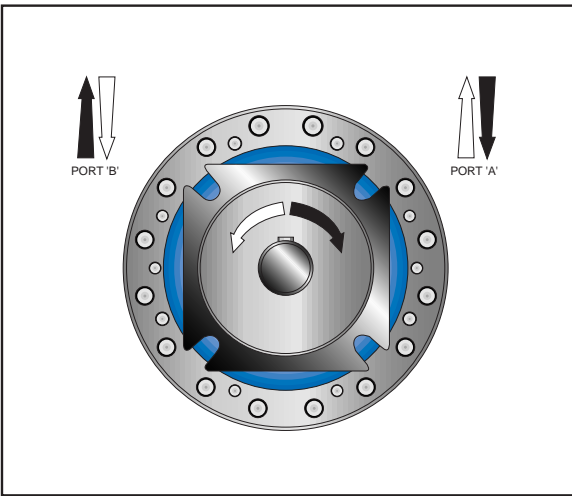
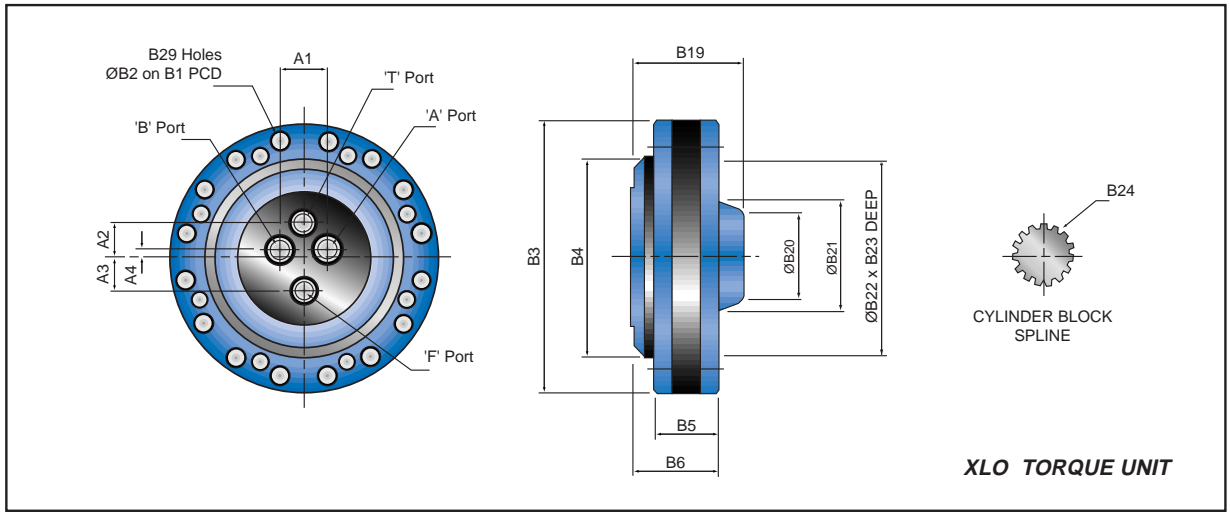

APPROXIMATE WEIGHTS Kg			
Weights	XL 15-28	XL 39-56	XL 78-11
XLO	21	30	35
XLA,B	28	43	48
XLC	26	39	44
XLE	28	43	48

IF IN DOUBT - CONSULT ROTARY POWER

## SPECIAL OPTIONS

### Air Bleed Port

For "shaft up" installations, an air bleed port should be specified and the leakage pipework should be arranged in a similar way to figure 1. This ensures that the bearings and the shaft seal are immersed in hydraulic oil.

If in doubt - please contact Rotary Power

Figure 1.

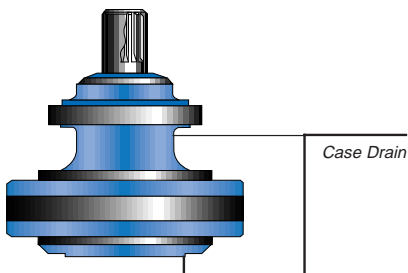

### Speed Indication

A pulse pick-up port may be specified. Consult Rotary Power regarding preferred number of pulses/revolution and pulse pick-up thread size. Contact Rotary Power if alternative types of speed indication are required.

### Mounting of Couplings or Gears to the Motor Shaft

Threaded holes can be included in the end of the shaft to assist the fitting of couplings, gears, etc. Consult Rotary Power for details.

### Special Features

Consult Rotary Power if a special feature is required. Where it is practical, Rotary Power will engineer a custom design to match the specific need.

### Flow Divider

Various flow divider configurations are possible. Please contact Rotary Power to discuss your requirements

**ORDER CODE**

**XL MOTOR BASIC MODEL CODE**  
**X L E 5 6 G N 0 0 0 - -**

**XL SERIES**

**OUTPUT CASE STYLE**

- O = Torque unit only
- A = SAE flange mount
- B = Metric flange mount
- C = Compact housing
- E = Wheel casing
- H = Torque unit fitted with "universal" gearbox adaptor

**DISPLACEMENT**

- 15 = 150 CM<sup>3</sup>
- 20 = 200 CM<sup>3</sup>
- 28 = 280 CM<sup>3</sup>
- 39 = 390 CM<sup>3</sup>
- 49 = 490 CM<sup>3</sup>
- 56 = 560 CM<sup>3</sup>
- 78 = 780 CM<sup>3</sup>
- 88 = 880 CM<sup>3</sup>
- 98 = 980 CM<sup>3</sup>
- 10 = 1050 CM<sup>3</sup>
- 11 = 1120 CM<sup>3</sup>

**XLE 56GN000 - -**

XLMotor  
 Wheel casing, 560 CC/Rev.  
 Standard wheel flange, Nitrile seals.  
 No special requirements  
 Design series - -

**DESIGN SERIES**  
 Factory specified

**SPECIAL REQUIREMENTS IN CONSULTATION WITH ROTARY POWER**  
 None = OO

**BRAKE OPTION**

- O = No brake
- B = Drum brake
- C = Disc brake

**SEALS**

- N = Nitrile (Standard)
- V = Viton

**OUTPUT SHAFT**

- O = Torque unit only
- A = SAE keyed shaft
- B = Metric keyed shaft
- C = XM keyed shaft
- D = SAE splined shaft
- E = Metric splined shaft
- F = XM splined shaft
- G = Wheel flange
- H = Taper shaft
- J = Quill shaft for option H case style
- K = HM keyed shaft